

# Operation Manual

ATT. Zone Amplifier  
**PAM-510/520**



**interM**

# Contents

<b>Welcome</b>	
Warning.....	1
Unpacking.....	2
<b>Installation</b>	
Environment.....	2
Important Safety Instructions.....	2
<b>Features</b> .....	3
Accessories.....	3
<b>Operation</b> .....	3
<b>Front Panel</b> .....	4
<b>Rear Panel</b> .....	6
<b>Connecting Speakers</b> .....	9
<b>Application of the Antenna</b> .....	10
<b>Applications</b> .....	11
<b>Block Diagram</b> .....	12
<b>Specifications</b> .....	13
<b>Service</b>	
Procedures.....	14
Schematic.....	14
Parts List .....	14
<b>Variations and Options</b> .....	14
<b>Warranty</b> .....	14

# Welcome

## A personal welcome to you from the management and employees of Inter-M

All of the co-workers here at Inter-M are dedicated to providing excellent products with inherently good value, and we are delighted you have purchased one of our products.

We sincerely trust this product will provide years of satisfactory service, but if anything is not to your complete satisfaction, we will endeavor to make things right.

Welcome to Inter-M, and thank you for becoming part of our worldwide extended family!

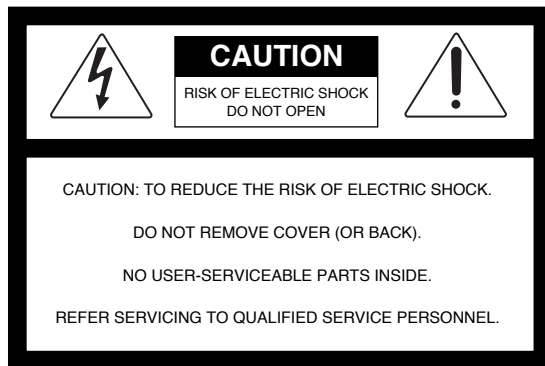

## WARNING

To prevent fire or shock hazard, do not expose the unit to rain or moisture.

\*Do not install this equipment in a confined space such as a book case or similar unit.

\*The apparatus shall not be exposed to dripping or splashing and no objects filled with liquids, such as vases, shall be placed on the apparatus.

\*Worded: "WARNING FOR YOUR PROTECTION PLEASE READ THE FOLLOWING-WATER AND MOISTURE: Unit should not be used near water(e.g. near a bathtub, washbowl, kitchen sink, laundry tub, in a wet basement, or near a swimming pool, etc). Care should be taken so than objects do not fall and liquids are not spilled into the enclosure through openings."



This symbol is intended to alert the user to the presence of uninsulated "dangerous voltage" within the product's enclosure that may be of sufficient magnitude to constitute a risk of electric shock to persons.



This symbol is intended to alert the user to the presence of important operation and maintenance (servicing) instructions in the literature accompanying the appliance.

Caution: To prevent electric shock do not use this (polarized) plug with an extension cord, receptacle or other outlet unless the blades can be fully inserted to prevent blade exposure.

Attentions: Pour prévenir les chocs électriques ne pas utiliser cette fiche polarisée avec un prolongateur, une prise de courant on une autre sortie de courant, sauf si les lames peuvent être insérées à fond sans en laisser aucune partie à découvert.

\* It can be heated up if you use this product in closed box or ill-ventilated place.

## Unpacking

Although your PAM-510 or PAM-520 is neither complicated nor difficult to operate, we recommend you take a few minutes to read this brief manual and familiarize yourself with the important information regarding product features, setup and operation.

As with most electronic devices, we strongly recommend you retain the original packaging. In the unlikely event the product must be returned for servicing, the original packaging (or reasonable equivalent) is required.

## Installation

### Environment

Never place this product in an environment which could alter its performance or reduce its service life. Such environments usually include high levels of heat, dust, moisture, and vibration.

### Important Safety Instructions

1. Read these instructions.
2. Keep these instructions.
3. Heed all warnings.
4. Follow all instructions.
5. Do not use this apparatus near water.
6. Clean only with dry cloth.
7. Do not block any ventilation openings. Install in accordance with the manufacturer's instructions.
8. Do not install near any heat sources such as radiators, heat registers, stoves, or other apparatus (including amplifiers) that produce heat.
9. Do not defeat the safety purpose of the polarized or grounding-type plug. A polarized plug has two blades with one wider than the other. A grounding type plug has two blades and a third grounding prong. The wide blade or the third prong are provided for your safety. If the provided plug does not fit into your outlet, consult an electrician for replacement of the obsolete outlet.
10. Protect the power cord from being walked on or pinched particularly at plugs, convenience receptacles, and the point where they exit from the apparatus.
11. Only use attachments/accessories specified by the manufacturer.
12. Use only with the cart, stand, tripod, bracket, or table specified by the manufacturer, or sold with the apparatus. When a cart is used, use caution when moving the cart/apparatus combination to avoid injury from tip-over.
13. Unplug this apparatus during lightning storms or when unused for long periods of time.
14. Refer all servicing to qualified service personnel. Servicing is required when the apparatus has been damaged in any way, such as power-supply cord or plug is damaged, liquid has been spilled or objects have fallen into the apparatus, the apparatus has been exposed to rain or moisture, does not operate normally, or has been dropped.



## Features

### - SPEAKER SELECT(5ZONE SPEAKER OUTPUT)

Six speaker select switches enable you to select any combination of up to five speakers.

### - SELECTABLE PRIORITY MUTING

Switchable audio signal priority for MIC Channels 1, siren, Chime and Telephone input over other input sources.

### - MONITOR SPEAKER

You can monitor output signal by using the monitor speaker, and can control the monitor level on front panel by 3 step lever switch.

### - ANNOUNCEMENT CHIME

Convenient four-tone chime for use with announcements.

### - REMOTE CONTROL INPUT

Individual speaker zones can be selected and chime can be operated by wired remote control.

### - EM(EMERGENCY)

When EM switch is pressed in emergencies, EM broadcasting stored in VOICE IC is outputted.

### - REMOTE POWER

You can turn on/off amplifier by remote control.

### - INDIVIDUAL INPUT GAIN CONTROLS

Rear-panel gain controls for each input channel for total control of individual levels.

### - MODULAR DESIGN

Optional modules can be installed in multiple configurations for convenience and ease of use. Choose the PAM-CDA (Compact Disc), PAM-T (AM/FM Tuner) or PAM-D (Cassette Deck) modules to expand the

## Accessories

One detachable AC power cord is provided for use with this product.

## Operation

Make certain that speakers and input sources are properly connected before switching on.

Keep volume levels turned down before switching on.

**NOTE:** The system's operation is delayed by approximately three seconds after pressing the power switch. This is due to the built-in protection circuitry, designed to protect the speakers and other system components.

## Front Panel

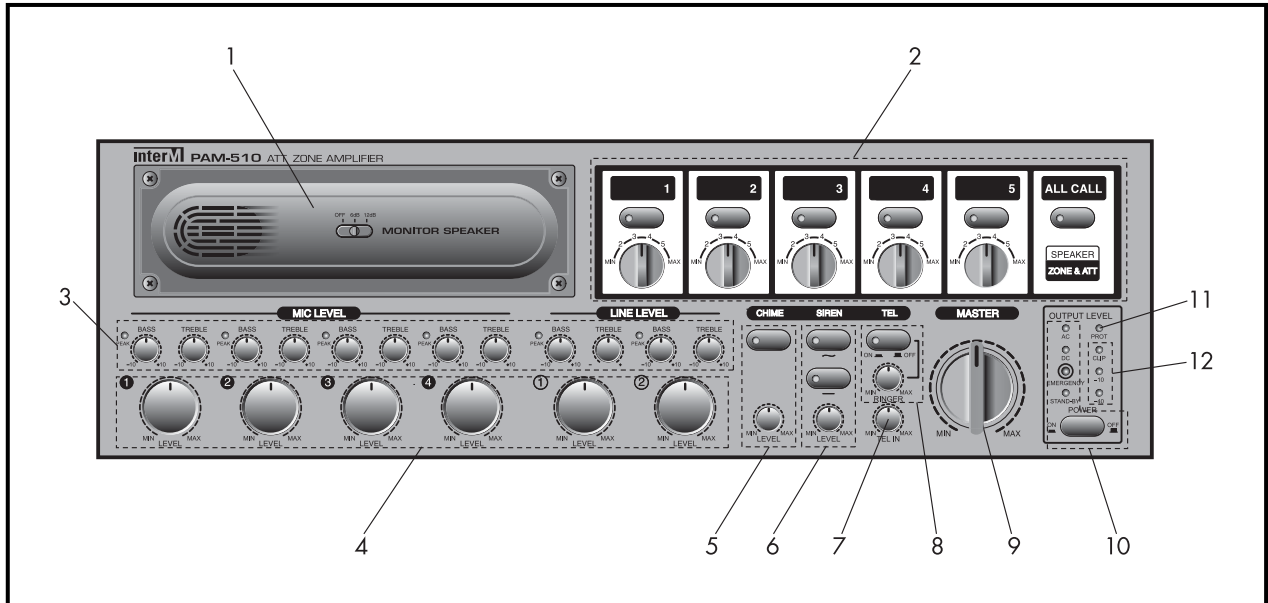

### 1. MONITOR SPEAKER

You can monitor output signal by using the monitor speaker, and can control the monitor level on front panel by 3 step lever switch.

These panels provide for installation of optional PAM-CDA, PAM-T or PAM-D Modules, via the unit's internal connectors.

### 2. SPEAKER SELECTOR & ATTENUATOR

These switches are used to select output to any combination of up to five individual speakers.

※Attenuator position and output Voltage.

	MIN	2	3	4	5	MAX
Output Voltage	6V	8.9V	12.5V	25V	50V	70V(USA/CANADA & Associated) 100V(EC & Associated)

### 3. TONE CONTROL AND PEAK INDICATOR

Individual Bass and Treble controls are used to cut (decrease) or boost (increase) the lower and higher frequencies  $\pm 12\text{dB}$ . This LED illuminates when the signal approaches clipping. If the PEAK indicator illuminates continuously (flashes often), you should decrease the level of input signal.

### 4. CHANNEL VOLUME

Controls the individual volume levels of Channels.

### 5. CHIME

Pressing this button will activate the one shot chime. Depending upon the volume adjustment the level of signal and mute level are varied.

**6. SIREN**

This is for emergency situation. Depending upon the volume adjustment the level of signal and mute level are varied.

(~) : Alert siren curve. (repeat)

(-) : Alert siren flat. (continuously)

**7. TEL IN**

Depending upon the volume adjustment the level of signal and mute level are varied.

**8. RINGER**

Night ringer function let you hear telephone ring via speaker.

Depending upon the volume adjustment the level of signal and Mute level are varied.

**9. MASTER VOLUME**

This rotary switch controls the overall output volume of the amplifier' s output signal.

**10. POWER SWITCH**

Pressing this switch turns the unit on, as indicated by the Power LED above the switch. Pressing it again turns the unit off. When the switch is to off location, becomes the stand-by condition and the STAND-BY LED lights.

**11. PROTECTION INDICATOR**

This LED indicates the state of the amplifier' s protection circuitry. When the Protection LED is on (illuminated), the protection circuitry is active, indicating that the unit is not operating normally. This is typically due to overheating or power limiting. Please check the Input and Output condition of the amplifier.

**12. OUTPUT LEVEL INDICATOR**

These three LEDs indicate the amplifier' s output status. The -40dB LED indicates the presence of audio signal at the amplifier' s output. The -10dB LED indicates output at nominal operating range. The red CLIP LED indicates an excessive output level. Do not operate the unit with the CLIP LED continuously on (illuminated).

# Rear Panel

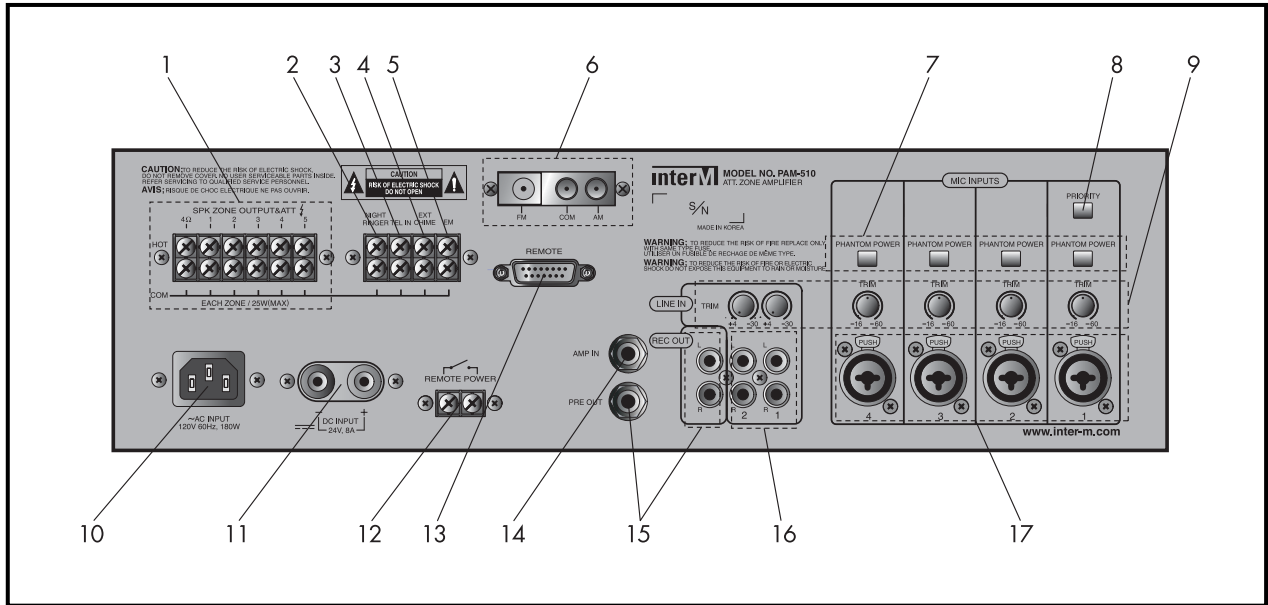

## 1. SPEAKER OUTPUT TERMINAL

This terminal is for speaker wire connection.

Connect speakers whose combined impedance is equal to or higher than the rated output impedance, as shown below.

Terminal Model Name \ Output	4Ω (LOW IMPEDANCE)	SPK 1~5 (HIGH IMPEDANCE)
PAM-510	22V/4Ω (120W)	EC & Associated : 100V/400Ω (25W MAX) USA/CANADA & Associated : 70V/196Ω (25W MAX)
PAM-520	31V/4Ω (240W)	EC & Associated : 100V/200Ω (50W MAX) USA/CANADA & Associated : 70V/98Ω (50W MAX)

## 2. NIGHT RINGER

Connect night ringer terminal to telephone line. You can telephone ring Via speaker from other office in the night.

## 3. TELEPHONE INPUT TERMINALS

These terminals can be connected to a telephone exchange system for paging purposes.

**NOTE:** When an active signal is sent through the telephone input, all other input signals except for AMP IN are muted.

## 4. EXT CHIME

When these two terminals are shorted by wired remote, the one shot chime is activated.



**5. EM(EMERGENCY)**

When EM switch is connected and pressed in fire or other emergencies, EM broadcasting stored in VOICE IC is outputted. When selected, these switches will give priority to over all other signals inputs.

**6. ANTENNA CONNECTOR(OPTIONAL)**

This terminal is used to connect the antenna, when used with the optional PAM-T AM/FM Tuner module.

**7. PHANTOM POWER SWITCH**

This switch turns the phantom power supply on or off for all channels. When the switch is turned on, +24V DC power is supplied to pins 2 and 3 of each channel's input connector.

Use phantom power when connecting condenser microphones, which require an external power supply.

**NOTE:** It is safe to connect most modern dynamic microphones or line level devices to the channel Inputs when phantom power is activated. However, some older ribbon microphones may be damaged by phantom power, and certain unbalanced line level devices may malfunction or produce an Audible hum when phantom power is active.

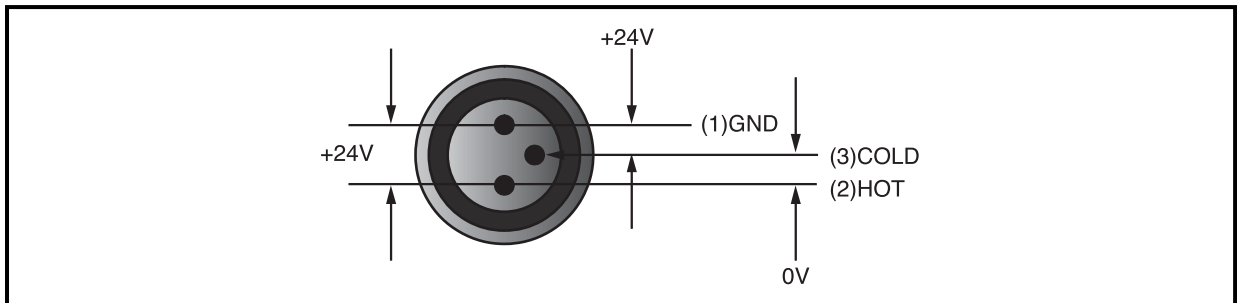
**8. MIC 1 PRIORITY SWITCH**

When selected, these switches will give priority to Channels 1 over all other channels inputs.

**9. INPUT GAIN CONTROLS(TRIM VR)**

These knobs provide continuous control of the input levels for each of the six input channels. When adjusting the input gain, make certain that the levels are not set too high, or distortion will result.

**10. AC POWER INPUT**

Connect a standard three-pin AC cable to this connector.

**11. DC INPUT TERMINALS**

These terminals are provided for the connection of backup battery. Connect a 24VDC 50A battery source to these terminals. Make certain the red terminal is connected to the battery's positive (+) side, and the black terminal to the battery's negative (-) side.

**12. REMOTE POWER**

You can turn on/off amplifier by remote control.

**13. REMOTE CONTROL INPUT**

By connecting a 15-pin D-SUB connector, it is possible to control speaker zone selection and activate the chime via wired remote. Connection terminals for the remote are shown below.

Pin 1: Remote amplifier input signal hot(+)	Pin 8: Remote control 5(Speaker 5)
Pin 2: Remote amplifier input signal cold(-)	Pin 9: Remote control ground
Pin 3: Signal ground	Pin 10: DC +24V
Pin 4: Remote control 1(Speaker 1)	Pin 11: Input Chime
Pin 5: Remote control 2(Speaker 2)	Pin 12: NC
Pin 6: Remote control 3(Speaker 3)	Pin 13: NC
Pin 7: Remote control 4(Speaker 4)	Pin 14, 15: NC

**14. AMP IN**

This input connects an external mixer or preamp with the unit's power amp. Inserting a plug into the Amp In jack will disconnect all input signal from the unit's internal mixer. Only signal from the external source will be heard.

**15. PRE OUT/REC OUT**

This output connects the unit with an external devices such as tape recorders or power amplifier. (OUTPUT LEVEL: REC OUT: -10dB, PRE OUT: 0dB )

**16. LINE INPUT CHANNEL 1~2**

This line-level input is an extra stereo input for a stereo source such as a tape deck or CD player.

**17. MIC INPUT CHANNEL 1~4**

This is a special connector which will accept either a 3-conductor XLR or a 3-conductor 1/4" jack. These inputs are suitable to receive signal from microphones level devices.

MIC JACK (XLR JACK)	LINE JACK (TRS PHONE JACK)
Pin 1: GROUND	Sleeve: GROUND
Pin 2: HOT(+)	Tip: HOT(+)
Pin 3: COLD(-)	Ring: COLD(-)

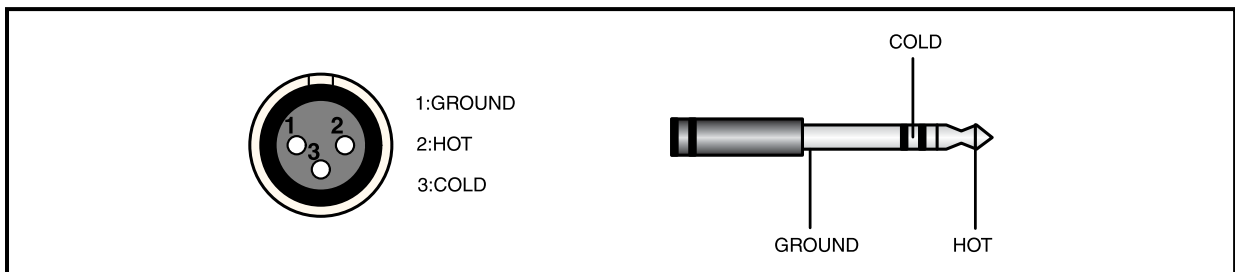

# Connecting Speakers

Before connecting speakers, disconnect the AC power cable. Note the proper connecting terminals as shown below. Make certain that the total impedance is not less than the rated impedance indicated.

## - CONNECTING HIGH-VOLTAGE DISTRIBUTED SPEAKER SYSTEMS

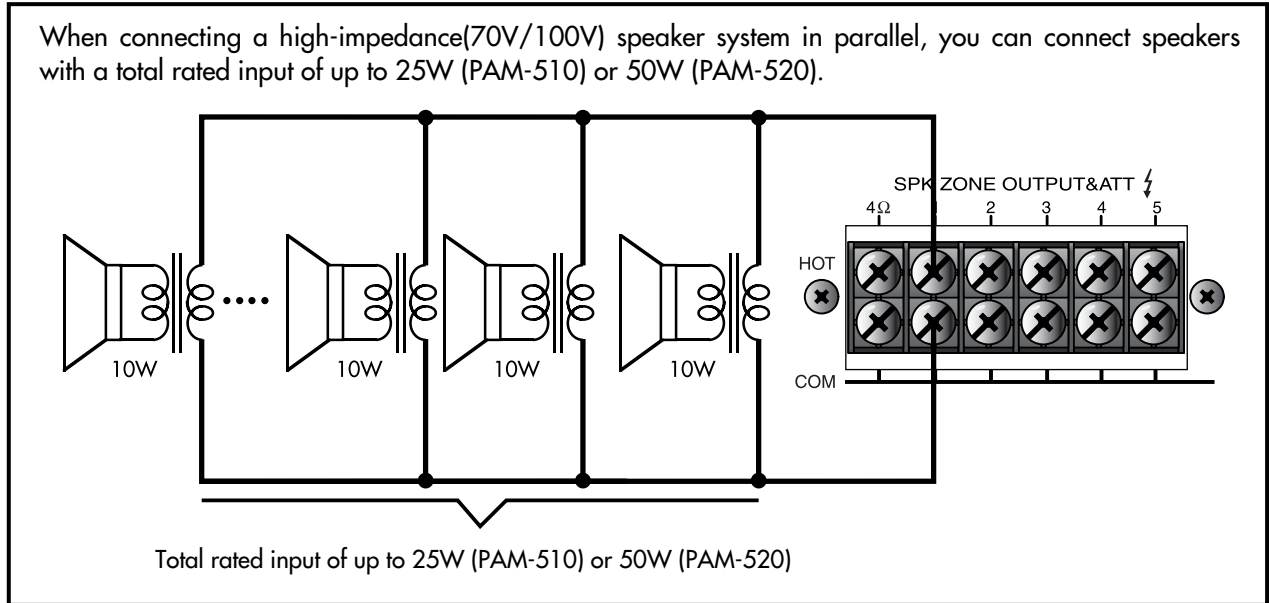

Terminal Model Name \ Output	4Ω (LOW IMPEDANCE)	SPK 1~5 (HIGH IMPEDANCE)
PAM-510	22V/4Ω (120W)	EC & Associated : 100V/400Ω (25W MAX) USA/CANADA & Associated : 70V/196Ω (25W MAX)
PAM-520	31V/4Ω (240W)	EC & Associated : 100V/200Ω (50W MAX) USA/CANADA & Associated : 70V/98Ω (50W MAX)

※**NOTE:** Be sure that total impedance is not less than rated impedance. (See upper chart.)

※**WARNING:** Extreme care must be exercised when connecting high-impedance systems, as potentially hazardous voltages may be present at these terminals.

Do not install this equipment in a confined space with less-than-adequate ventilation.

## Application of the Antenna

### - FM RECEIVING ANTENNA

The electric wave of FM broadcasting is weakening in hills and valleys, around buildings and in iron-reinforced buildings.

### - INSTALLATION OF ANTENNA EXCLUSIVELY FOR FM

Listening to the broadcasting, fix the antenna after deciding the location and the direction so that the reception may be optimized.

### - INSTALLATION OF ANTENNA USING THE COAXIAL CABLE

Noisy reception may occur in built-up areas and factory sites as well as around power cables. This may be the case even when an antenna is used exclusively for FM. In these regions, install the antenna using 75Ω coaxial cable.

### - INDOOR ANTENNA

In the regions where FM broadcasting is heard comparatively well due to the near distance to the station or wooden structure, you can receive broadcasting of good quality by using T-type antenna.(using matching trans:300Ω/75Ω)

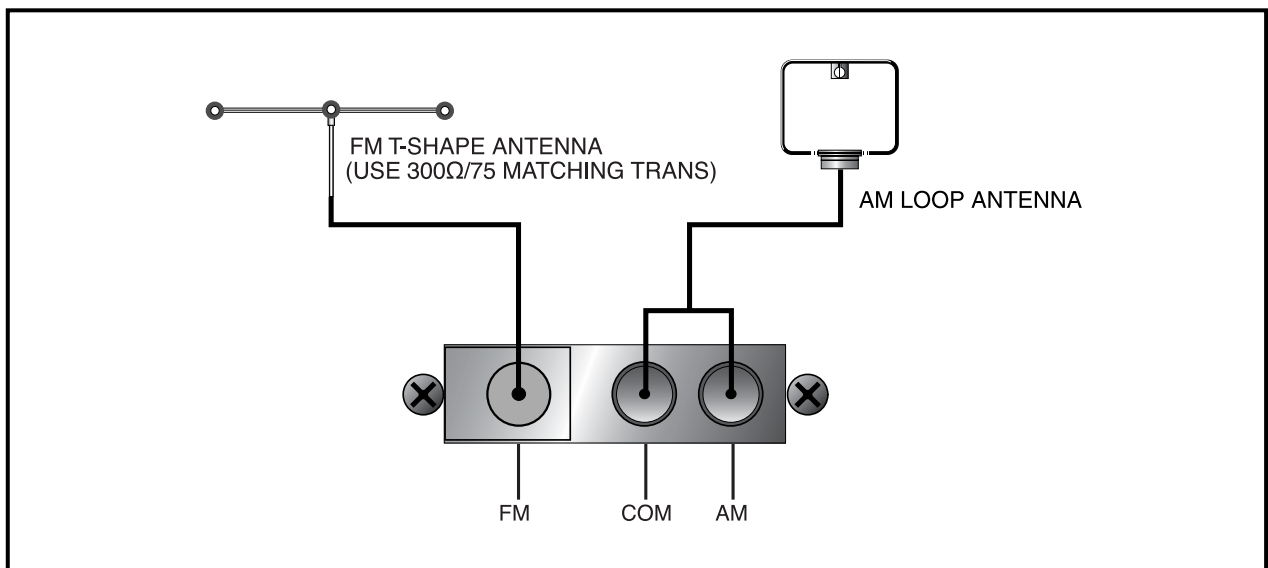

### - AM LEAD ANTENNA

Fix one end of a six to eight metre length of vinyl-coated single cable to the AM terminal and the other end to a high place like a wall.

### - AM OUTDOOR ANTENNA

Install the vinyl-coated cable to an outdoor place if the AM reception is not good enough.

### - AM LOOP ANTENNA

Connecting the feeder of the loop antenna of the terminal of 300Ω.

Listening to the broadcasting, fix it after deciding the location and the direction so that the receipt condition may be optimum.

# Applications

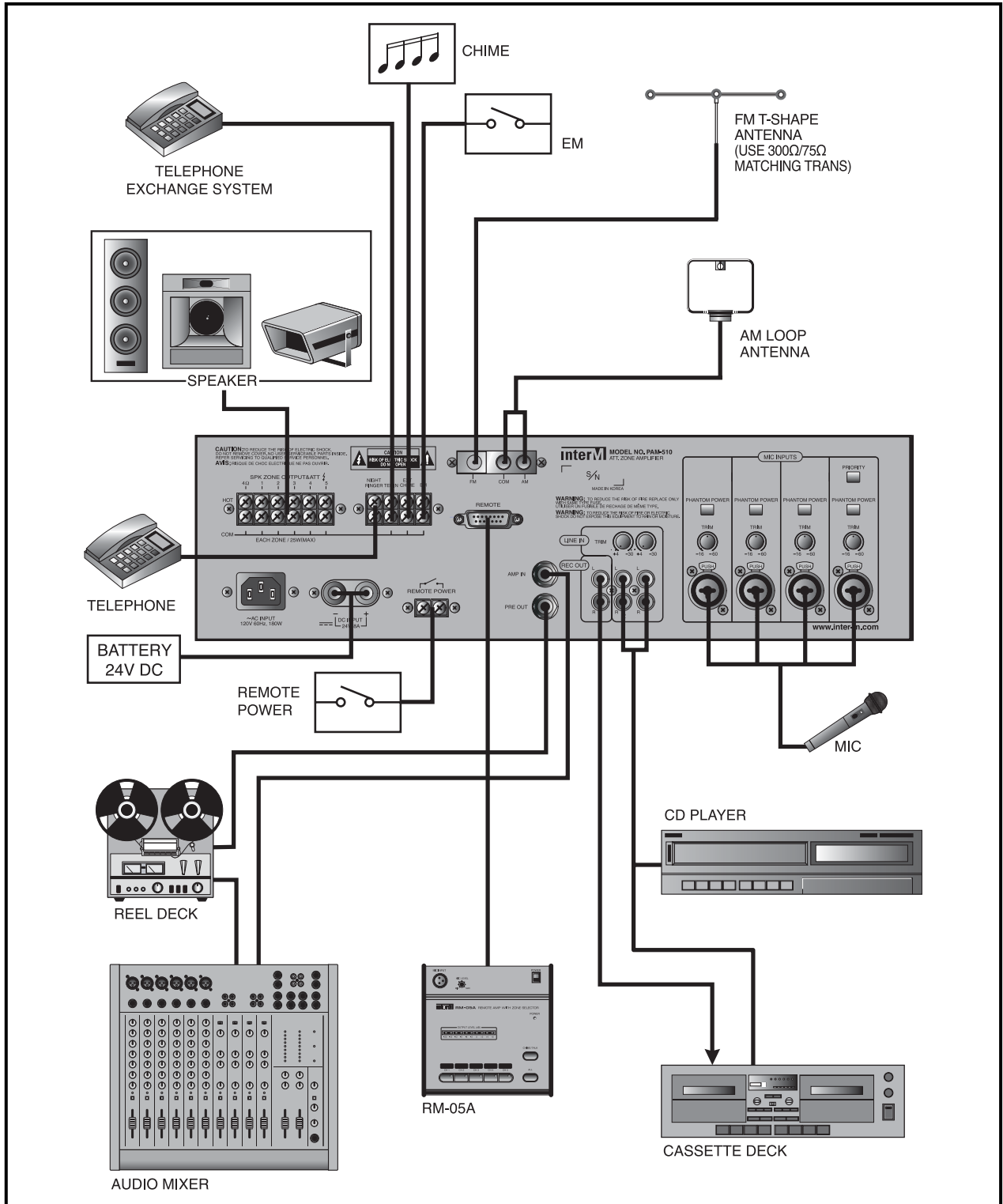

# Block Diagram

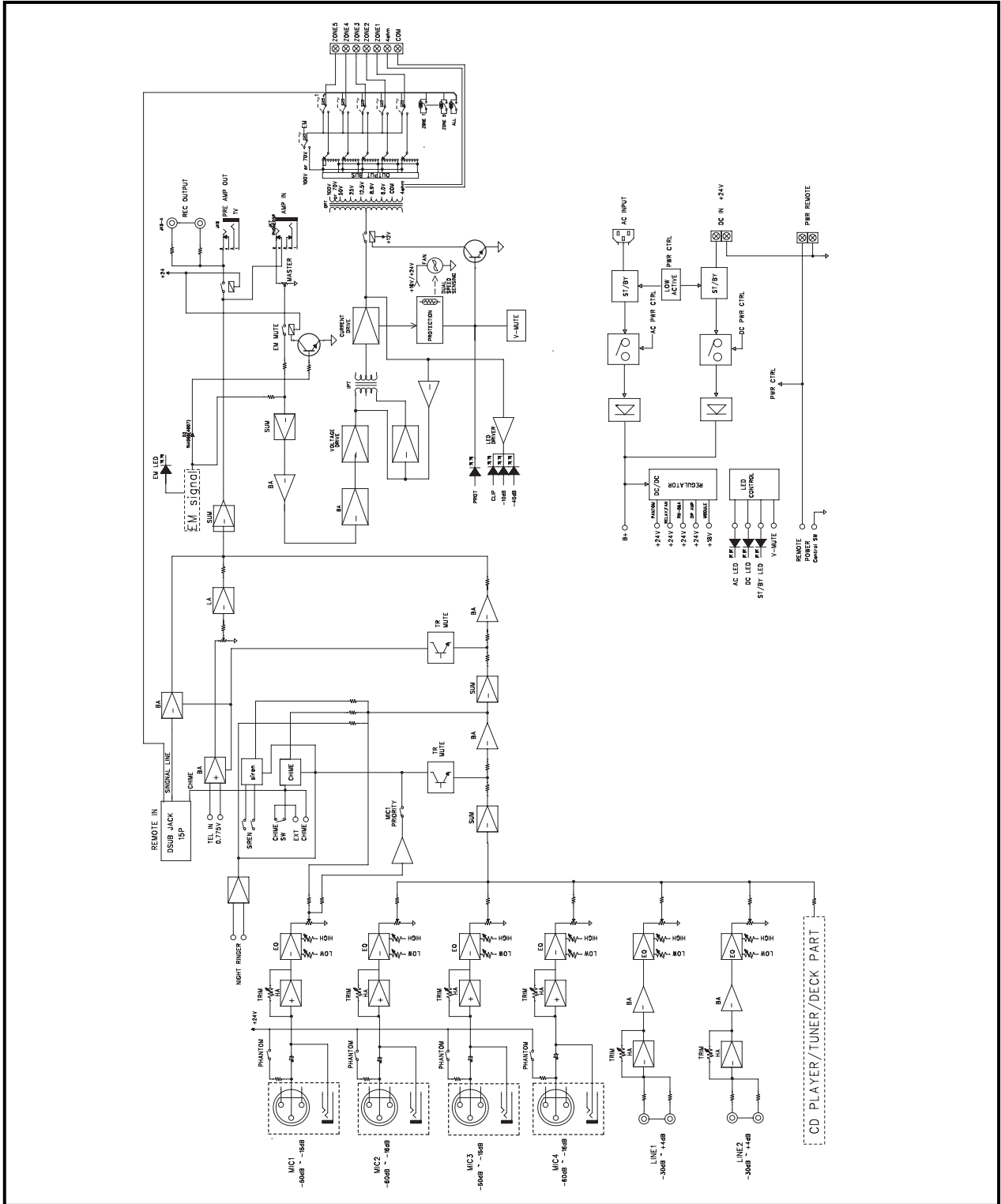

# Specifications

\*0dBV=1Vrms

		PMA-510	PAM-520
Amplifier Section (Amp In@1kHz, 4Ω Load Output)	Rated Output Power (THD 1%)	120W(RMS)	240W(RMS)
	Speaker Zone 1~5 Output	25W MAX	50W MAX
	Input Sensitivity/Impedance	1V/20kΩ	
	S/N	Better than 85dB	
	Frequency Response (at 1kHz Half Power Output, ±3dB)	80Hz~18kHz	
Mic Input Section (Mic 1~4 In@1kHz, Preamp Out)	Input Sensitivity/Impedance	-60dBV/600Ω	
	S/N	Better than 55dB	
	Frequency Response (±3dB)	120Hz~10kHz	
	Tone Control (Bass:100Hz,Treble:10kHz)	±12dB	
	Phantom Power	+24VDC	
Line Input Section (Line 1~2 In@1kHz, Preamp Out)	Input Sensitivity/Impedance	-30dBV/10kΩ	
	S/N	Better than 65dB	
	Frequency Response (±3dB)	80Hz~15kHz	
	Tone Control (Bass:100Hz,Treble:10kHz)	±12dB	
Remote Amp Section (Remote In@1kHz, Preamp Out)	Mic Input Sensitivity/Impedance	-60dBV/600Ω	
	S/N	Better than 55dB	
	Frequency Response (±3dB)	120Hz~10kHz	
Tel In Section (Tel In@1kHz, Preamp Out)	Input Sensitivity/Impedance	0.3V/600Ω(USA/Canada)	
		0.775V/600Ω(EC & Associated)	
	S/N	Better than 65dB	
	Frequency Response (±3dB)	330Hz~3kHz	
Pre Amp Out(Mic 1~4, Line 1~2, Tel In, Remote In)		0dBV/600Ω	
	T.H.D	Less than 0.5%	
Record Out		-10dBV/3kΩ	
Operating Temperature		-10°C~40°C	
Power Source		100~120VAC or 220~240VAC; 50/60Hz, 24VDC	
Power Consumption (1/8 POWER)		180W	320W
Weight		17kg/37.6lb	19kg/42lb
Dimensions		482(W) x 132(H) x 398(D)mm 19(W) x 5.2(H) x 15.7(D)in	

\* Specifications and design subject to change without notice.

## Service

### Procedures

Ensure the problem is not related to operator error, or system devices that are external to this unit. Information provided in the troubleshooting portion of this manual may help with this process. Once it is certain that the problem is related to the product contact your warranty provider as described in the warranty section of this manual.

### Schematic

A Schematic is available by contacting your warranty provider.

### Parts List

A Parts List is available by contacting your warranty provider.

## Variations and Options

### Variations

Products supplied through legitimate sources are compatible with local AC power requirements.

### Options

No optional items are available for this product.

## Warranty

Warranty terms and conditions vary by country and may not be the same for all products. Terms and conditions of warranty for a given product may be determined first by locating the appropriate country which the product was purchased in, then by locating the product type.

To obtain specific warranty information and available service locations contact Inter-M directly (in Korea or the USA) or the authorized Inter-M Distributor for your specific country or region.





Inter-M, Ltd. (Korea) began operations in 1983.

Since then, Inter-M has grown to become one of the largest manufacturers of professional audio and commercial sound electronics equipment in the world.

Inter-M has gained worldwide recognition for its own branded products, as well as private label manufacturing of electronics sold under other names (OEM).

The company is no longer just a Korean company, but rather a global company that is truly international in scope, with factories and offices in Korea and China, and sales and marketing operations located in Japan, Europe, and the U.S.A.

With more than 850 employees around the globe, Inter-M is well-poised for further growth and expansion.

**INTER-M AMERICAS, INC.**

1 EAST BEACON LIGHT LANE CHESTER, PA USA 19013-4409

TEL : 1-610-874-8870, FAX : 1-610-874-8890

Home Page : <http://www.inter-m.net>, E-mail : [service@inter-m.net](mailto:service@inter-m.net)

**INTER-M Corporation**

SEOUL OFFICE:653-5 BANGHAK-DONG, DOBONG-KU, SEOUL, KOREA

TEL : 82-2-2289-8140~8, FAX : 82-2-2289-8149

Home Page : <http://www.inter-m.com>, E-mail : [export@inter-m.com](mailto:export@inter-m.com)

MADE IN KOREA  
April 2006 9007504510