

ARCHI210

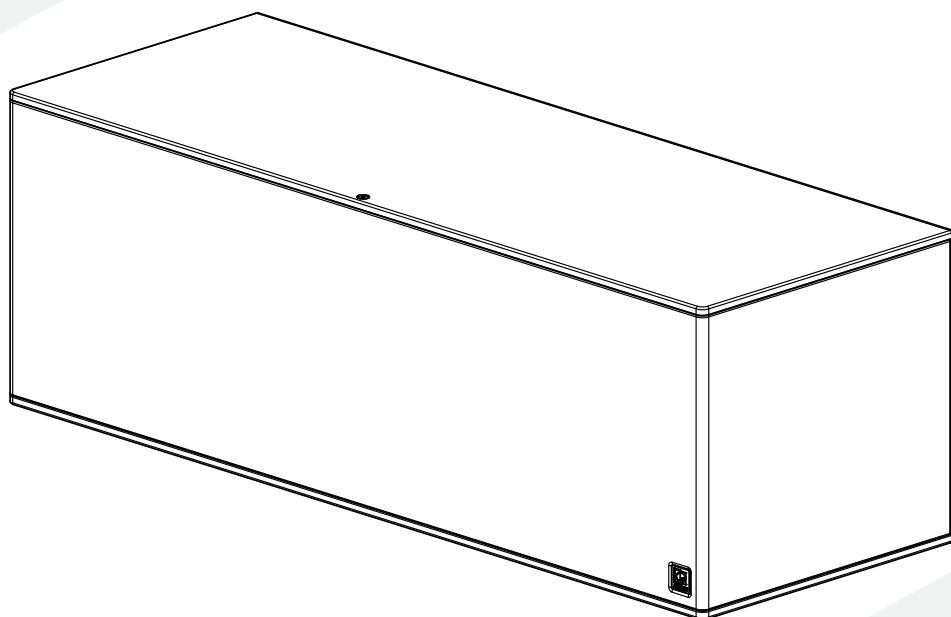

| | |
|--|-----------|
| Introduction | 03 |
| Compact double 10" architectural subwoofer | 03 |
| Precautions | 04 |
| Chapter 1 | 06 |
| Overview and connecting ARCHI210 | 06 |
| Chapter 2 | 07 |
| Installing ARCHI210 | 07 |
| Technical specifications | 09 |

ADDITIONAL INFORMATION

This manual is put together with much care, and is as complete as could be on the publication date. However, updates on the specifications, functionality or software may have occurred since publication. To obtain the latest version of both manual and software, please visit the Audac website @ www.audac.eu.



Compact double 10” architectural subwoofer

The ARCHI Series combines architectural elegance with groundbreaking audio performance. Designed for bars, restaurants, hospitality, and residential applications, these compact subwoofers deliver immersive sound with minimal visual impact.

Featuring innovations like AcoustiMesh for acoustic neutrality, AeroVent for noise-free bass performance, and weatherproof capabilities, the ARCHI Series excels indoors and outdoors. With low-frequency extensions down to 26Hz, flexible mounting options, and durable materials, the ARCHI Series redefines low-frequency fidelity, offering powerful, precise bass in a discreet, stylish design.

The ARCHI210 takes performance to the next level with its dual-driver bass reflex design, engineered to deliver immersive, distortion-free bass. The AcoustiMesh acoustic neutral 3D fabric ensures sound clarity, while the polyurea-coated 15mm MDF enclosure offers durability and stability. Equipped with ultra-vented gap cooling, the ARCHI210 minimizes power compression, ensuring consistent performance even at high power levels. With the added flexibility to switch nominal impedance between 4 and 16 ohms, the ARCHI210 adapts seamlessly to various system configurations. Its weatherproof treated cone enhances durability, making it a robust choice for long-term use in high-demand environments. Designed for versatility, this model excels in delivering rich, powerful bass with precision and control.

Precautions



READ FOLLOWING INSTRUCTIONS FOR YOUR OWN SAFETY

ALWAYS KEEP THESE INSTRUCTIONS. NEVER THROW THEM AWAY

ALWAYS HANDLE THIS UNIT WITH CARE

HEED ALL WARNINGS

FOLLOW ALL INSTRUCTIONS

NEVER EXPOSE THIS EQUIPMENT TO RAIN, MOISTURE, ANY DRIPPING OR SPLASHING LIQUID. AND NEVER PLACE AN OBJECT FILLED WITH LIQUID ON TOP OF THIS DEVICE

NO NAKED FLAME SOURCES, SUCH AS LIGHTED CANDLES, SHOULD BE PLACED ON THE APPARATUS

DO NOT INSTALL THIS UNIT NEAR ANY HEAT SOURCES SUCH AS RADIATORS OR OTHER APPARATUS THAT PRODUCE HEAT

DO NOT PLACE THIS UNIT IN ENVIRONMENTS WHICH CONTAIN HIGH LEVELS OF DUST, HEAT, MOISTURE OR VIBRATION

THIS UNIT IS DEVELOPED FOR INDOOR USE ONLY. DO NOT USE IT OUTDOORS

ONLY USE ATTACHMENTS & ACCESSORIES SPECIFIED BY THE MANUFACTURER

CAREFULLY CHECK THE UNIT'S CONDITION AFTER UNPACKING. IF THERE IS ANY DAMAGE TO THE CARTON BOX OR THE UNIT ITSELF, INFORM YOUR VENDOR IMMEDIATELY.

USE CABLES OF THE RIGHT GAUGE TO CONNECT THE LOUDSPEAKER

USE CABLES WITH CLEAR COLOUR CODING INDICATING THE POLARITY AND MAINTAIN THE SAME POLARITY THROUGHOUT THE WHOLE SYSTEM.

ONLY USE THE CORRECT AMPLIFIER OUTPUT VOLTAGE AND IMPEDANCE. EXCEEDING THESE LIMITS COULD CAUSE FIRE OR OTHER FAILURES.

AVOID EXPLOSIONS: DO NOT USE THE SPEAKER AROUND GASOLINE, THINNER OR OTHER COMBUSTIBLES

AVOID ELECTRIC SHOCKS: SWITCH OFF THE AMPLIFIER WHEN CONNECTING THE LOUDSPEAKER

DO NOT USE THE LOUDSPEAKER FOR AN EXTENDED PERIOD OF TIME AT DISTORTED SOUND. THIS COULD CAUSE PERMANENT DAMAGE.

**CAUTION - SERVICING**

This product contains no user serviceable parts. Refer all servicing to qualified service personnel. Do not perform any servicing (unless you are qualified to)

**EC DECLARATION OF CONFORMITY**

This product conforms to all the essential requirements and further relevant specifications described in following directives: 2014/30/EU (EMC2) & 2014/35/EU (LVD).

**WASTE ELECTRICAL AND ELECTRONIC EQUIPMENT (WEEE)**

The WEEE marking indicates that this product should not be disposed with regular household waste at the end of its life cycle. This regulation is created to prevent any possible harm to the environment or human health.

This product is developed and manufactured with high quality materials and components which can be recycled and/or reused. Please dispose this product at your local collection point or recycling centre for electrical and electronic waste. This will make sure that it will be recycled in an environmentally friendly manner, and will help to protect the environment in which we all live.

Overview and connecting ARCHI210

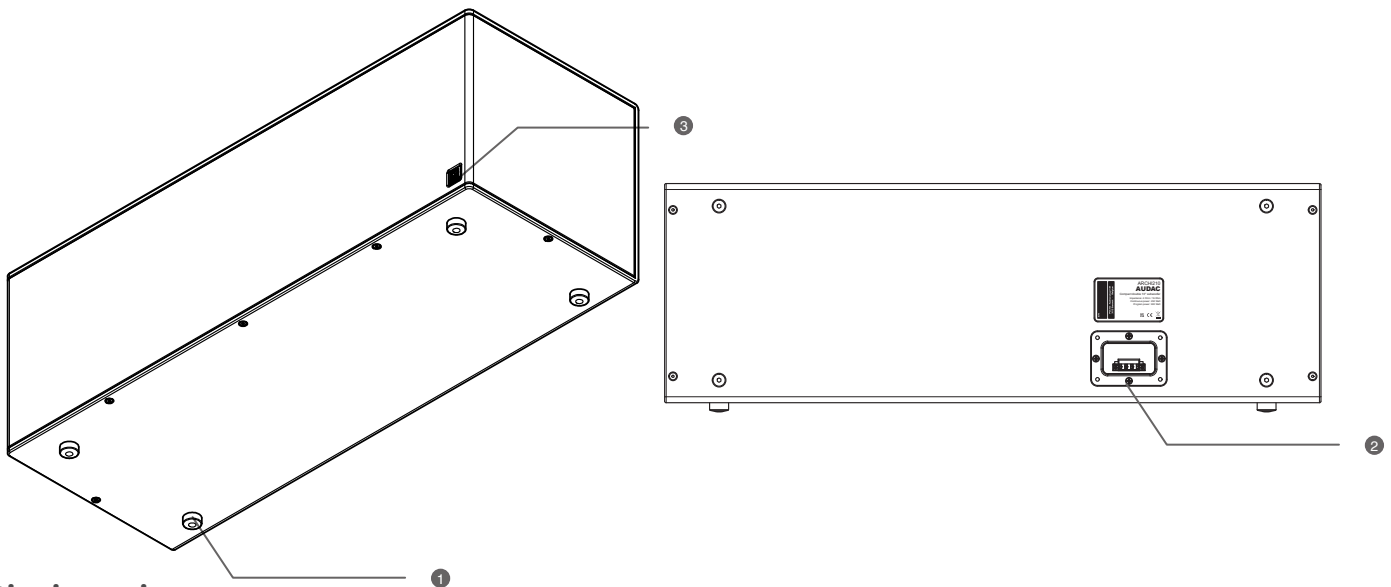

1) Rigging points

Rigging points are available on ARCHI series for optional mounting brackets. These brackets allow flexible and secure mounting on walls and ceilings to achieve an architectural discreet pleasing installation.

2) Terminal block connector

The wires from the amplifier should be connected to the terminal block located on the back of the ARCHI210 subwoofer. This connector ensures a secure and reliable connection, making it ideal for fixed installations.

The ARCHI210 allows flexible impedance configuration, offering the ability to switch between 4 Ohm and 16 Ohm operation. Details can be found in Chapter 2, under “Changing impedance 4 Ohm / 16 Ohm”.

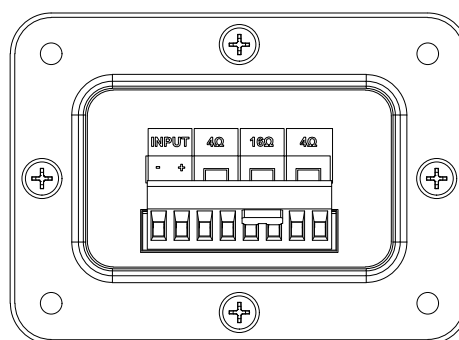

3) Rotatable logo

The ARCHI210 is designed for flexible deployment, allowing both vertical and horizontal installation to suit different architectural needs. To complement this versatility, the AUDAC logo can also be rotated easily—no tools required. Simply pull the logo out slightly and rotate it to match the speaker’s orientation for a seamless, professional look in any setup.

Installing ARCHI210

1) Placement

The low frequencies produced by the AUDAC ARCHI series subwoofers are naturally omnidirectional, meaning their placement within a space is flexible. However, following a few key guidelines can significantly enhance performance and efficiency.

For optimal dispersion, low-frequency speakers perform best when positioned close to the ground. This is why ARCHI subwoofers are typically floor-mounted rather than attached to walls or ceilings, unless necessary. Additionally, placing the subwoofer near boundaries, such as walls or floors, reinforces bass output by naturally increasing sound pressure levels. Positioning a subwoofer in a room corner further enhances low-frequency response due to boundary coupling.

When using multiple ARCHI subwoofers, placing them side by side enhances acoustic coupling, resulting in greater sound pressure levels and a more impactful bass response. However, in some applications—depending on room size, layout, and acoustic characteristics—a wider dispersion may be preferable to achieve balanced coverage.

Since ideal subwoofer placement depends on the specific application, experimenting with positioning and coupling can help optimize performance for the best possible listening experience.

2) Connection

The ARCHI210 subwoofer is equipped with a terminal block connector easy and secure wiring, ensuring a seamless setup.

Since the ARCHI210 does not include an internal low-pass filter, the input signal should be processed using an external crossover, a DSP-controlled amplifier. WaveDynamics presets are available in the latest version of AUDAC Touch to achieve optimal performance.

Mind the polarity markings when wiring the loudspeaker cables.

3) Changing impedance 4 Ohm / 16 Ohm

The ARCHI210 allows flexible impedance configuration, offering the ability to switch between 4 Ohm and 16 Ohm operation. This adaptability ensures compatibility with different amplifier setups and system designs.

Ensure the correct jumper placement before powering the system to achieve the desired impedance setting.

To adjust the impedance:

4 Ohms (Default configuration): Two connection bridge between the 4 Ohm terminals

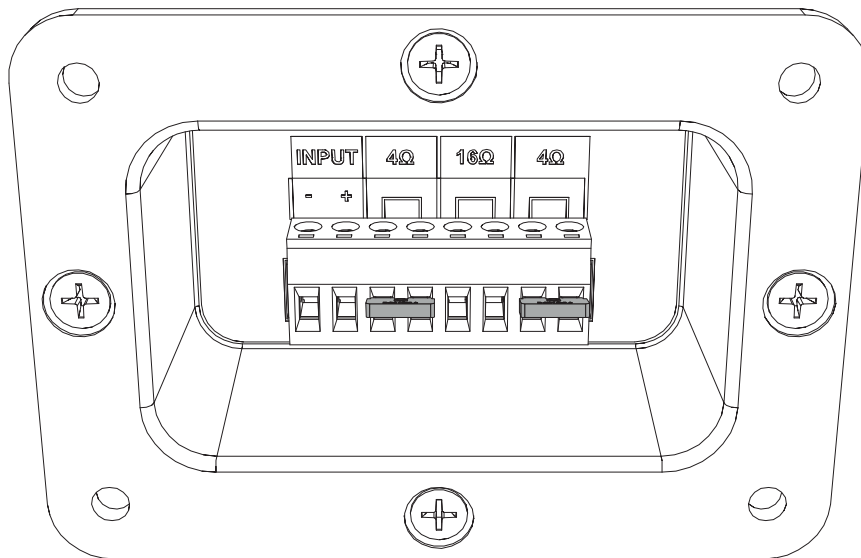

16 Ohms: Single connection bridge between 16 Ohm terminals.

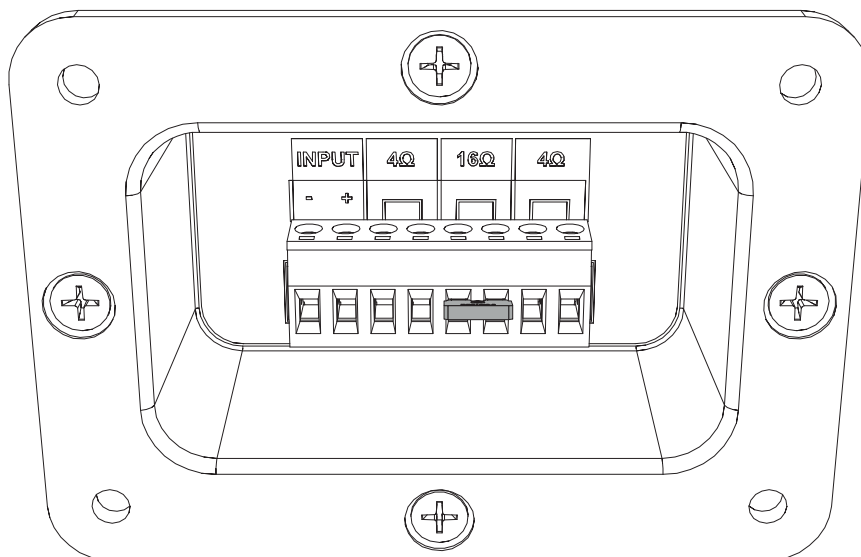

Technical specifications



| ARCHI210 | |
|----------------------------|---|
| Speaker type | 10" Infra-sub |
| Peak power handling | 1800W |
| Program power handling | 900W |
| Continuous power (AES) | 450W |
| Nominal impedance | 4 Ohm / 16 Ohm |
| Max SPL (Continuous) | 128 dB |
| Sensitivity 1W/1m | 101 dB |
| Frequency response (- 3dB) | 65 Hz - 120 Hz |
| Frequency range (-10dB) | 47 Hz - 200 Hz |
| Bass port tuning frequency | 51 Hz |
| Connectors | Terminal block |
| Drivers | 2x10" Ferrite with low-loss suspension and 15" 4-layer wounded voice coil |
| Dimensions (w x h x d) | 868 x 290 x 318 mm (excluding feet) |
| | 868 x 302 x 318 mm (including feet) |
| Weight | 23.1 kg |
| Operating temperature | -20 °C ~ 70 °C |
| Construction | 15 mm MDF with multi-layer Polyurea coating |
| Front finish | AcoustiMesh |
| Colours | Black & White |



Discover more on audac.eu